





## Table of Contents

Coversheet.....	1
Table of Contents .....	2
Record of Revision.....	3
1 General Specifications .....	4
2 Input/Output Terminals .....	5
3 Absolute Maximum Ratings .....	6
4 Electrical Characteristics.....	7
5 Timing Chart.....	9
6 Optical Characteristics .....	15
7 Environmental / Reliability Tests.....	19
8 Mechanical Drawing .....	20
9 Packing Drawing .....	21
10 Precautions for Use of LCD Modules .....	22





## 1 General Specifications

	Feature	Spec
<b>Display Spec.</b>	Size	2.2 inch
	Resolution	240(RGB) x 320
	Interface	CPU 18 bits
	Color Depth	262K
	Technology Type	a-Si TFT
	Pixel Pitch (mm)	0.1395X0.1395
	Pixel Configuration	R.G.B. Vertical Stripe
	Display Mode	TM with Normally White
	Surface Treatment(Up Polarizer)	Clear Type(3H)
	Viewing Direction	6 o'clock
	Gray Scale Inversion Direction	12 o'clock
<b>Mechanical Characteristics</b>	LCM (W x H x D) (mm)	40.10x55.20x2.10
	Active Area(mm)	33.48x44.64
	With /Without TSP	Without TSP
	Weight (g)	5.8
	LED Numbers	4 LEDs
<b>Electronic</b>	Driver IC	ILI9325

Note 1: Viewing direction for best image quality is different from TFT definition, there is a 180 degree shift.

Note 2: Requirements on Environmental Protection: RoHS

Note 3: LCM weight tolerance :  $\pm 5\%$



## 2 Input/Output Terminals

### 2.1 TFT LCD Panel

No	SYMBOL	I/O	Description	Remark
1	GND1	P	Power	
2	VC1	P	Power	
3	VCC1	P	Power	
4	/CS	I	Chip select	
5	RS	I	Register select	
6	/WR	I	Write	
7	/RD	I	Read	
8	/RESET	I	Reset	
9	DB0	I	Data bus	
10	DB1	I	Data bus	
11	DB2	I	Data bus	
12	DB3	I	Data bus	
13	DB4	I	Data bus	
14	DB5	I	Data bus	
15	DB6	I	Data bus	
16	DB7	I	Data bus	
17	DB8	I	Data bus	
18	DB9	I	Data bus	
19	DB10	I	Data bus	
20	DB11	I	Data bus	
21	DB12	I	Data bus	
22	DB13	I	Data bus	
23	DB14	I	Data bus	
24	DB15	I	Data bus	
25	DB16	I	Data bus	
26	DB17	I	Data bus	
27	LED_A	P	LED power	
28	LED_K1	P	LED power	
29	LED_K2	P	LED power	
30	LED_K3	P	LED power	
31	LED_K4	P	LED power	
32	GND2	P	Power	

Note 1: I/O definition:

I----Input O---Output P----Power(Ground)



### 3 Absolute Maximum Ratings

#### 3.1 Driving TFT LCD Panel

Ta = 25°C

Item	Symbol	Min.	Max.	Unit	Remark
Supply Voltage	VC1/ VCC1	-0.3	4.6	V	
Input Signal Voltage	DB0~DB17,/CS,RS,/WR,/RD,/RESET	-0.3	VCC +0.3	V	
Back Light Forward Current	I <sub>LED</sub>	--	25	mA	For each LED
Operating Temperature	T <sub>OPR</sub>	-20	70	°C	
Storage Temperature	T <sub>STG</sub>	-30	80	°C	



## 4 Electrical Characteristics

### 4.1 Driving TFT LCD Panel

GND=0V, Ta=25°C

Item		Symbol	Min.	Typ.	Max.	Unit	Remark
Logic Supply Voltage		VCC1	1.65	2.8	3.3	V	
Analog supply voltage		VC1	2.5	2.8	3.3	V	
Input Signal Voltage	Low Level	V <sub>IL</sub>	0	--	0.2xVCC1	V	DB0~DB17,/CS,RS, /WR,/RD,/RESET
	High Level	V <sub>IH</sub>	0.8xVCC1	--	VCC1	V	
Output Signal Voltage	Low Level	V <sub>OL</sub>	-0.3	--	0.3xVCC1	V	
	High Level	V <sub>OH</sub>	0.7xVCC1	--	VCC1	V	
(Panel+ LSI) Power Consumption		Black Mode (60Hz)	--	14	--	mW	Frame rate 60Hz, VCC1=2.8V, VC1=2.8V
		Standby Mode	--	89	--	uW	
		Sleeping Mode	--	210	--	uW	

### 4.2 Driving Backlight

Ta=25°C

Item	Symbol	Min.	Typ.	Max.	Unit	Remark
Forward Current	I <sub>F</sub>	--	72	100	mA	4 LEDs ( in parallel)
Forward Voltage	V <sub>F</sub>	--	3.2	3.5	V	
Power Consumption	W <sub>BL</sub>	--	230	350	mW	

Note1: Figure below shows the connection of backlight LED.

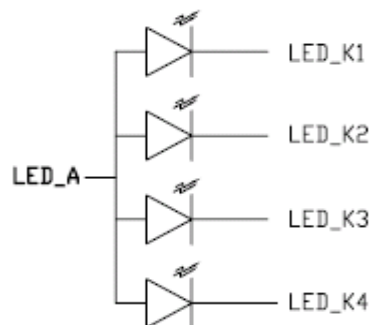

Note 2: One LED : I<sub>F</sub> =18 mA, V<sub>F</sub> =3.2V

Note 3: The life of LED : 20,000 hours

The information contained herein is the exclusive property of SHANGHAI TIANMA MICRO-ELECTRONICS Corporation, and shall not be distributed, reproduced, or disclosed in whole or in part without prior written permission of SHANGHAI TIANMA MICRO-ELECTRONICS Corporation.



### 4.3 Block Diagram

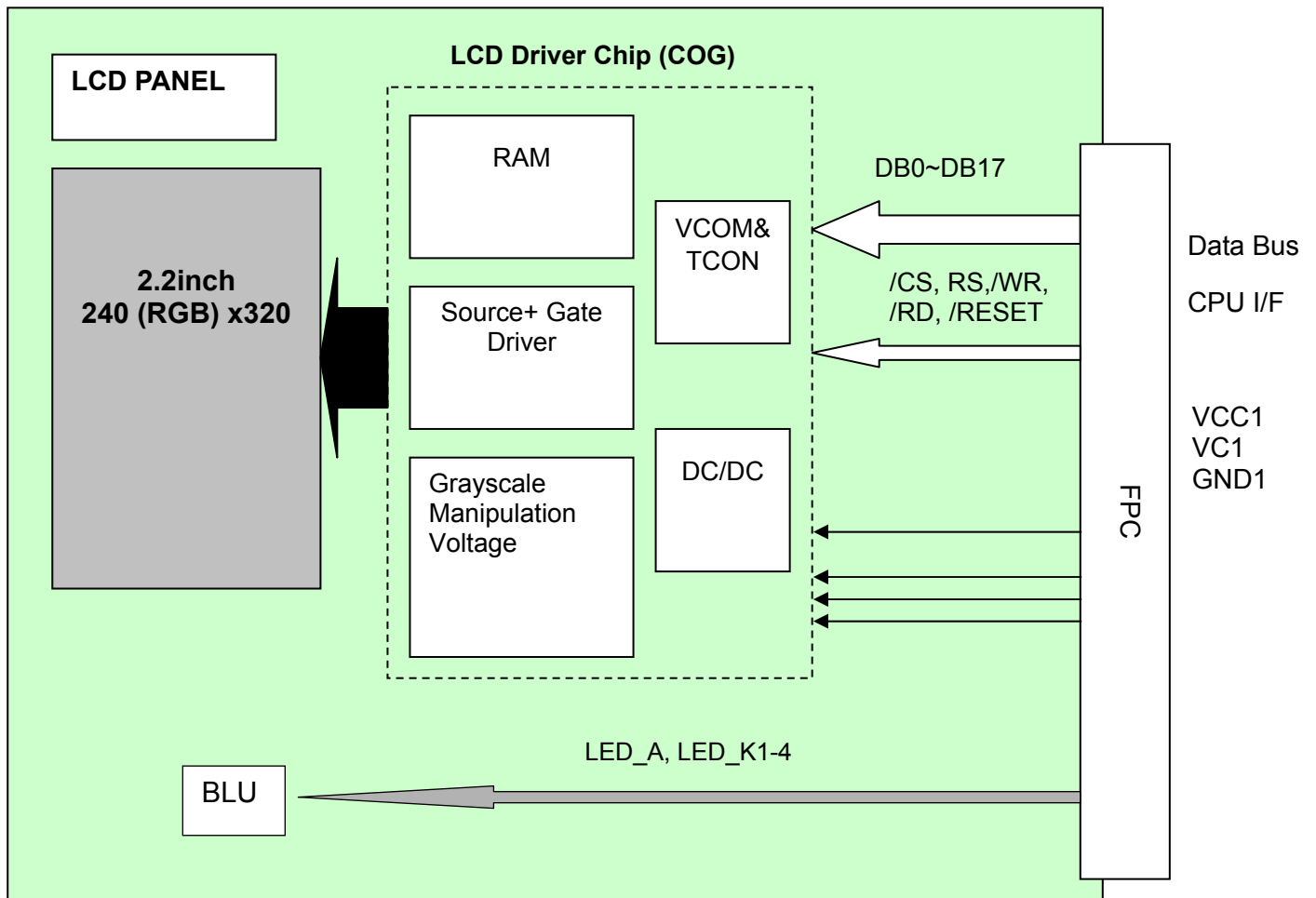



## 5 Timing Chart

### 5.1 I80 System Timing Parameter

Normal Write Mode (VCC1=2.5~3.3V)

Item		Symbol	Unit	Min.	Typ.	Max.	Test Condition
Bus cycle time	Write	$t_{CYCW}$	ns	100	-	-	
	Read	$t_{CYCR}$	ns	300	-	-	
Write low-level pulse width		$PW_{LW}$	ns	50	-	500	
Write high-level pulse width		$PW_{HW}$	ns	50	-	-	
Read low-level pulse width		$PW_{LR}$	ns	150	-	-	
Read high-level pulse width		$PW_{HR}$	ns	150	-	-	
Write / Read rise / fall time		$t_{WRr}/t_{WRf}$	ns	-	-	25	
Setup time	Write ( RS to /CS, E/WR )	$t_{AS}$	ns	10	-	-	
	Read ( RS to /CS, RW/RD )			5	-	-	
Address hold time		$t_{AH}$	ns	5	-	-	
Write data set up time		$t_{DSW}$	ns	10	-	-	
Write data hold time		$t_H$	ns	15	-	-	
Read data delay time		$t_{DDR}$	ns	-	-	100	
Read data hold time		$t_{DHR}$	ns	5	-	-	



## 5.1.1 I80 System Bus Timing

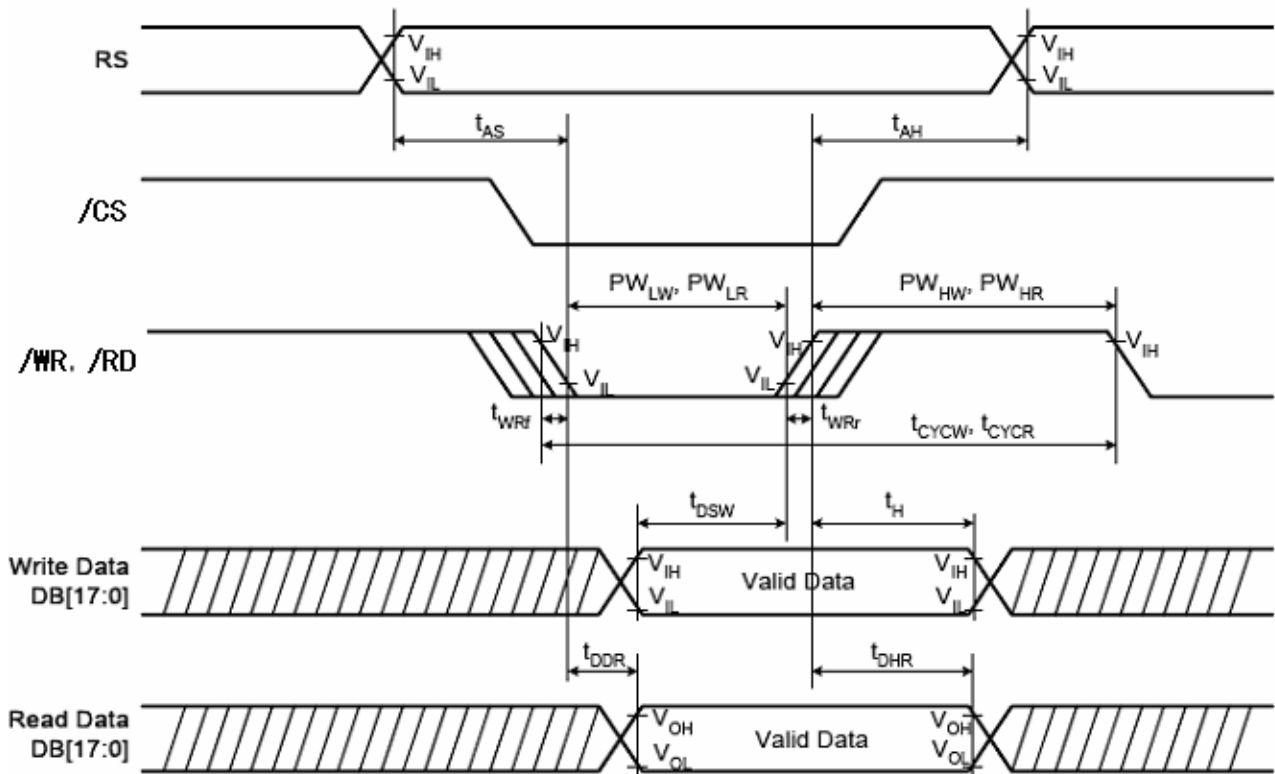



### 5.1.2 Register write timing in I80 series system

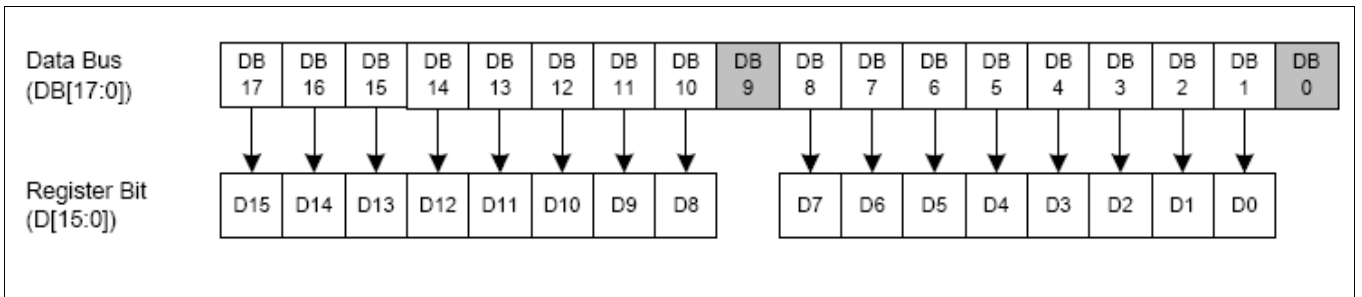
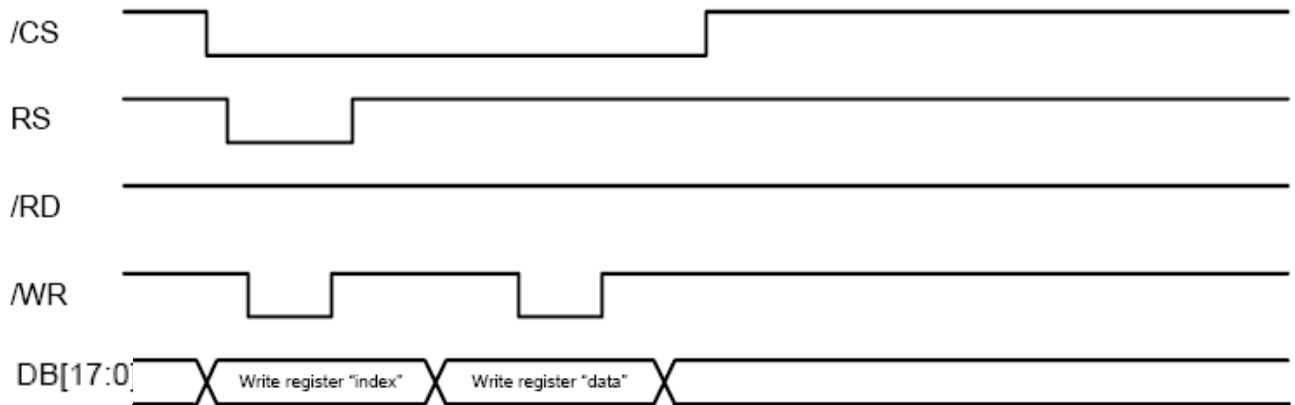



5.1.3 GRAM write timing in I80 series system

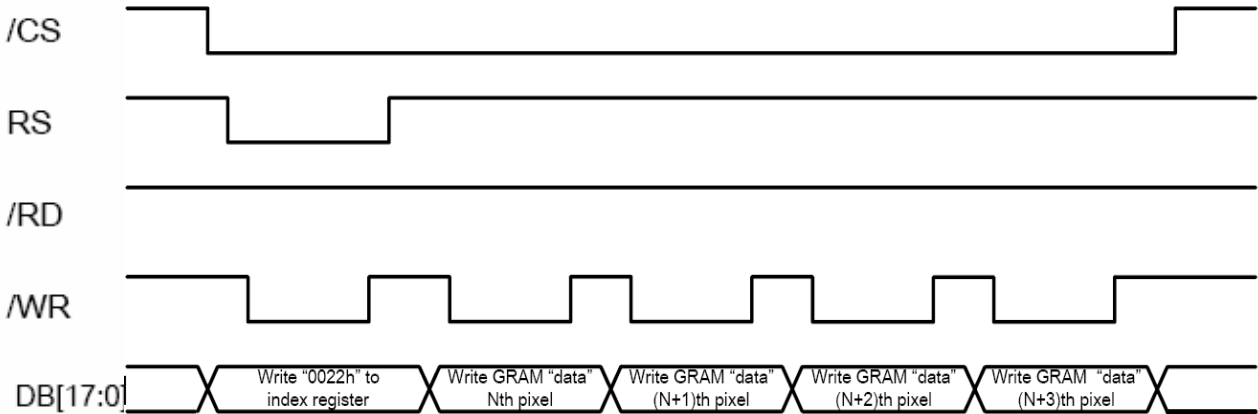

18-bit System Interface (262K colors) TRI=0, DFM[1:0]=00

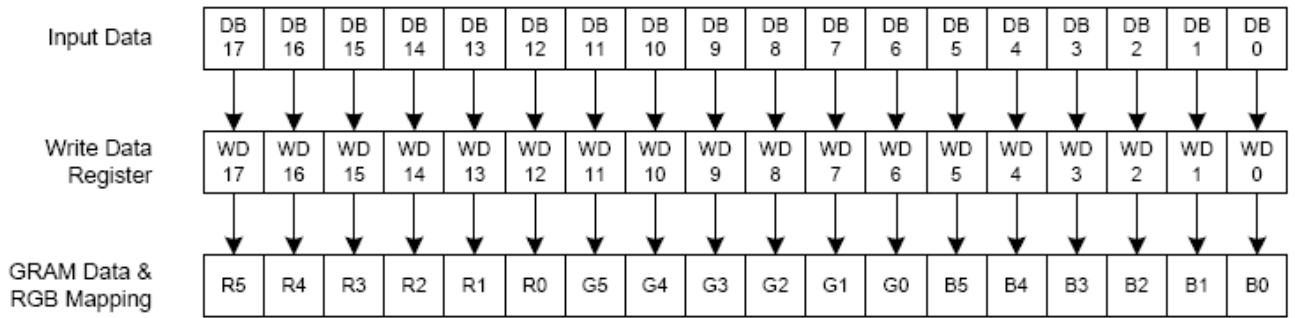

GRAM Data format of 18-bit system

5.1.4 Reset Timing Characteristics

Item	Symbol	Unit	Min.	Typ.	Max.
Reset low-level width	$t_{RES}$	ms	1	-	-
Reset rise time	$t_{rRES}$	$\mu s$	-	-	10

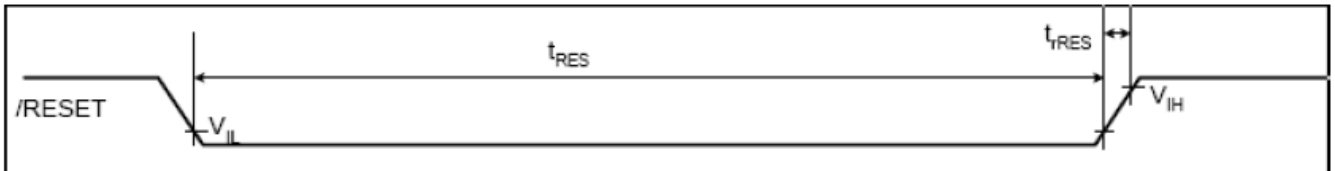

The information contained herein is the exclusive property of SHANGHAI TIANMA MICRO-ELECTRONICS Corporation, and shall not be distributed, reproduced, or disclosed in whole or in part without prior written permission of SHANGHAI TIANMA MICRO-ELECTRONICS Corporation.



### 5.2 Power On/Off sequence

#### 5.2.1 Power on Sequence

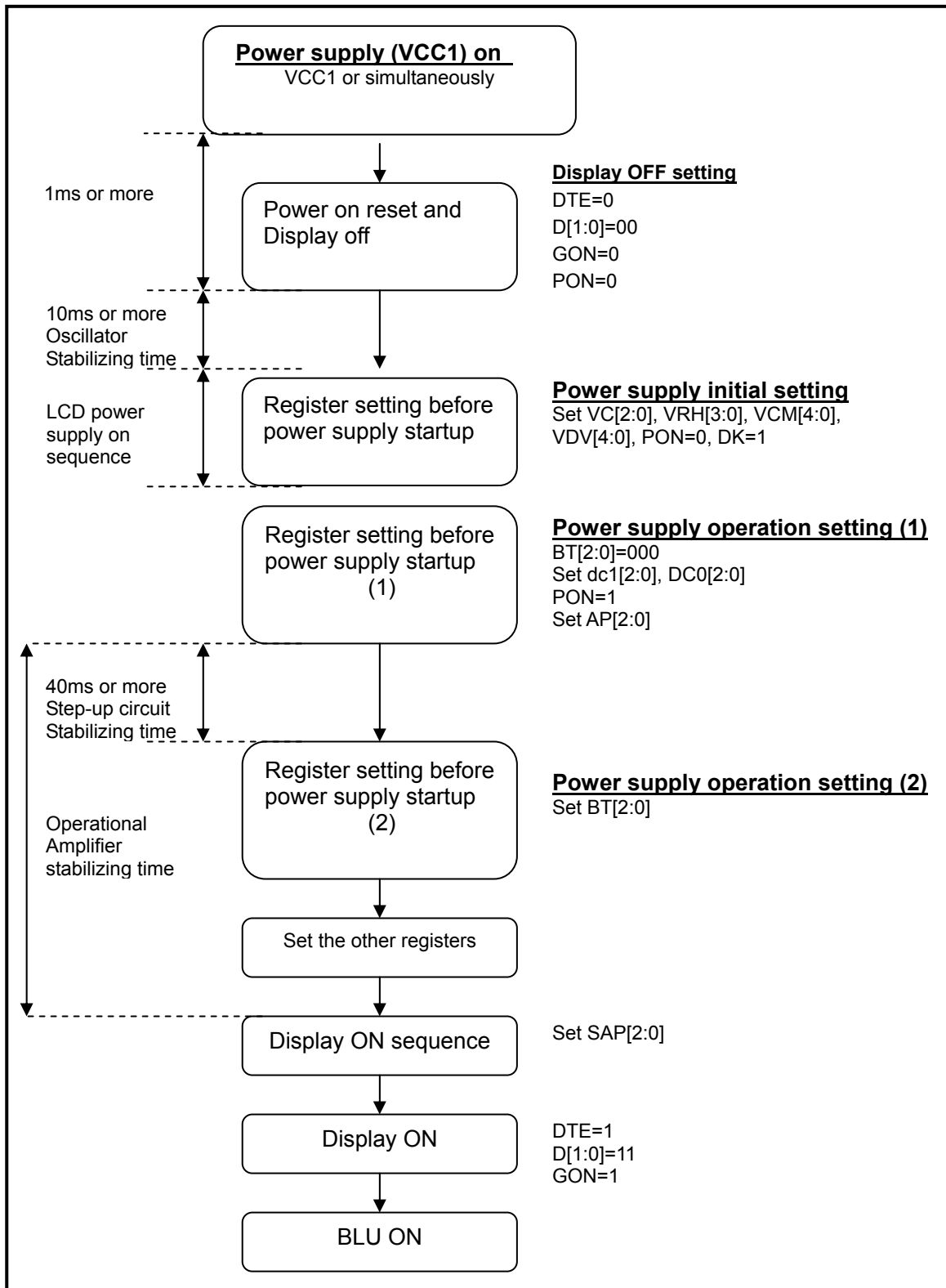

The information contained herein is the exclusive property of SHANGHAI TIANMA MICRO-ELECTRONICS Corporation, and shall not be distributed, reproduced, or disclosed in whole or in part without prior written permission of SHANGHAI TIANMA MICRO-ELECTRONICS Corporation.



### 5.2.2 Power off Sequence

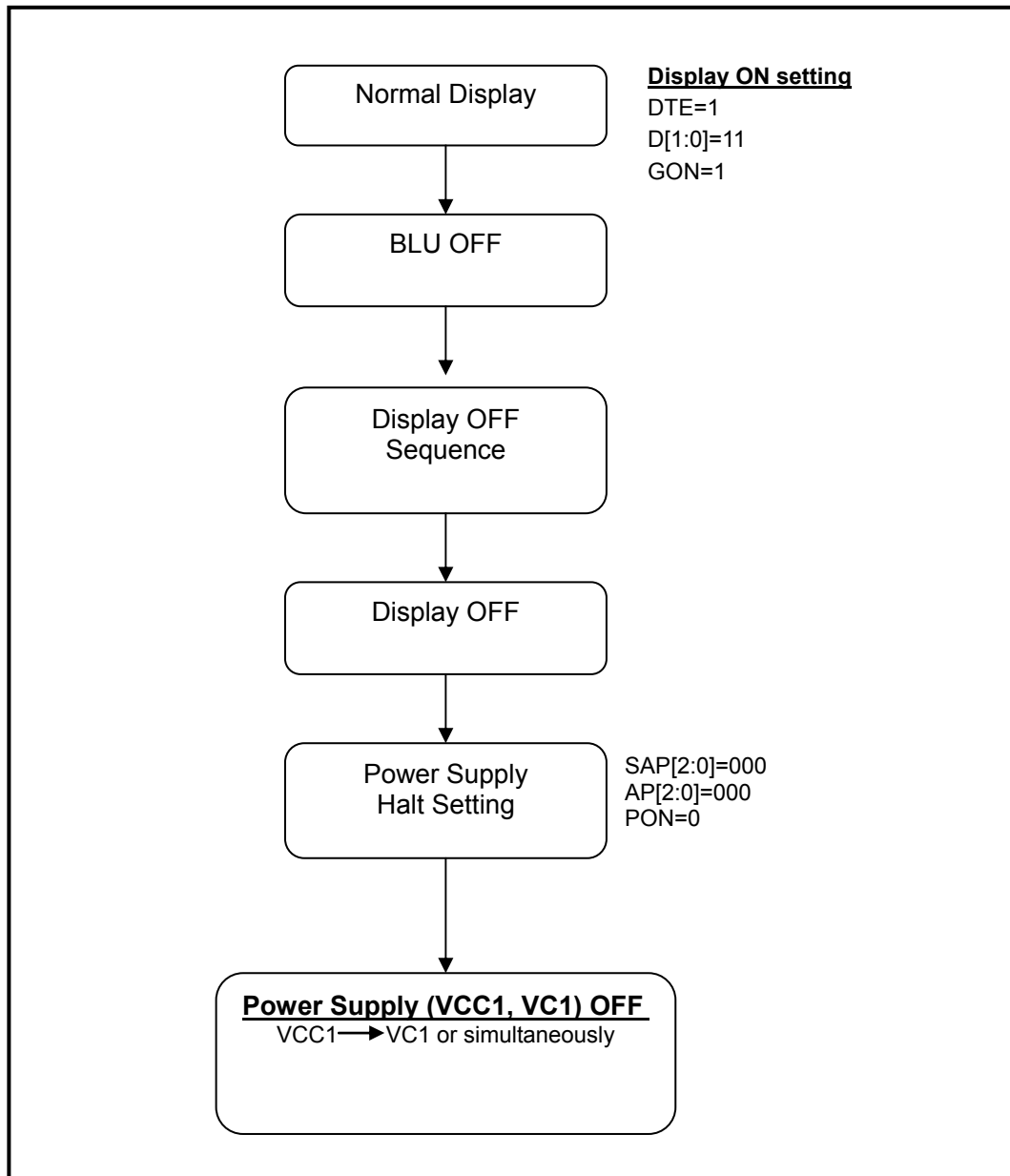



## 6 Optical Characteristics

### 6.1 Optical Specification

Ta=25°C

Item	Symbol	Condition	Min.	Typ.	Max.	Unit	Remark
View Angles	$\theta T$	$CR \cong 10$	50	60	-	Degree	Note 2
	$\theta B$		30	40	-		
	$\theta L$		50	60	-		
	$\theta R$		50	60	-		
Contrast Ratio	CR	$\theta=0^\circ$	200	350	-		Note1 Note3
Response Time	$T_{ON}$	25°C	-	25	40	ms	Note1 Note4
	$T_{OFF}$						
Chromaticity	White	x	Backlight is on	0.245	0.295	0.345	Note5, Note1
		y		0.256	0.316	0.356	
	Red	x		0.558	0.608	0.658	
		y		0.279	0.329	0.379	
	Green	x		0.271	0.321	0.371	
		y		0.559	0.609	0.659	
	Blue	x		0.094	0.144	0.194	
		y		0.046	0.096	0.146	
Uniformity	U		75	80	-	%	Note1 Note6
NTSC			-	62	-	%	Note 5
Luminance	L		140	180	-	cd/m <sup>2</sup>	Note1 Note7

Test Conditions:

- $V_F = 3.2V$ ,  $I_F = 18mA$  (One LED current), the ambient temperature is 25°C.
- The test systems refer to Note 1 and Note 2.



Note 1: Definition of optical measurement system.

The optical characteristics should be measured in dark room. After 5 minutes operation, the optical properties are measured at the center point of the LCD screen. All input terminals LCD panel must be ground when measuring the center area of the panel.

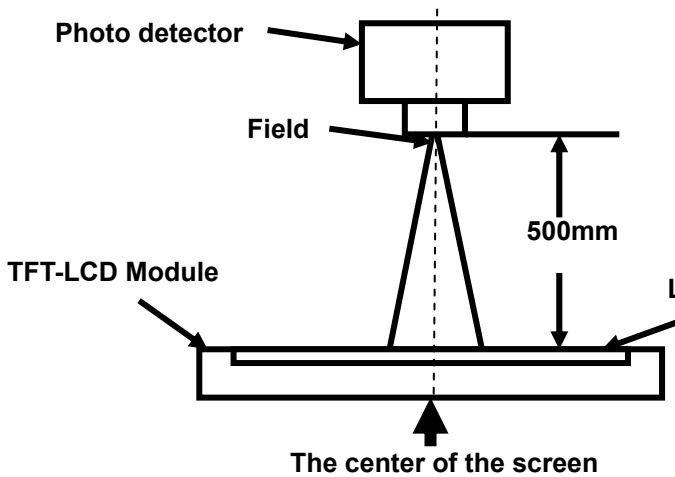

Item	Photo detector	Field
Contrast Ratio	SR-3A	1°
Luminance		
Chromaticity		
Lum Uniformity		
Response Time	BM-7A	2°

Note 2: Definition of viewing angle range and measurement system.

viewing angle is measured at the center point of the LCD by CONOSCOPE(ergo-80).

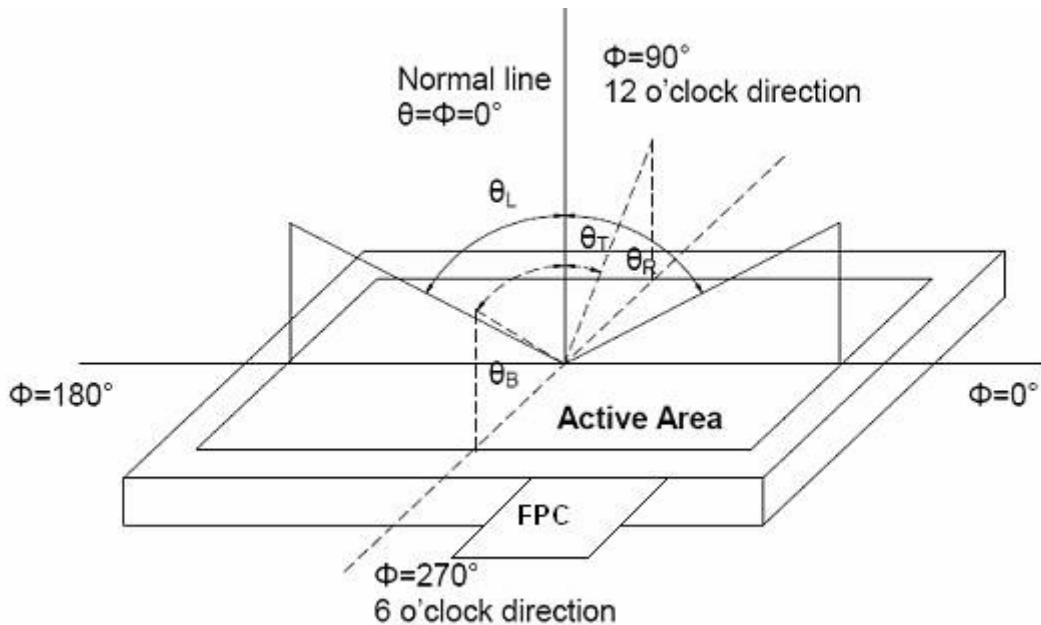

Fig. 1 Definition of viewing angle



Note 3: Definition of contrast ratio

$$\text{Contrast ratio (CR)} = \frac{\text{Luminance measured when LCD is on the "White" state}}{\text{Luminance measured when LCD is on the "Black" state}}$$

“White state “:The state is that the LCD should be driven by  $V_{\text{white}}$ .

“Black state”: The state is that the LCD should be driven by  $V_{\text{black}}$ .

$V_{\text{white}}$ : To be determined     $V_{\text{black}}$ : To be determined.

Note 4: Definition of Response time

The response time is defined as the LCD optical switching time interval between “White” state and “Black” state. Rise time ( $T_{\text{ON}}$ ) is the time between photo detector output intensity changed from 90% to 10%. And fall time ( $T_{\text{OFF}}$ ) is the time between photo detector output intensity changed from 10% to 90%.

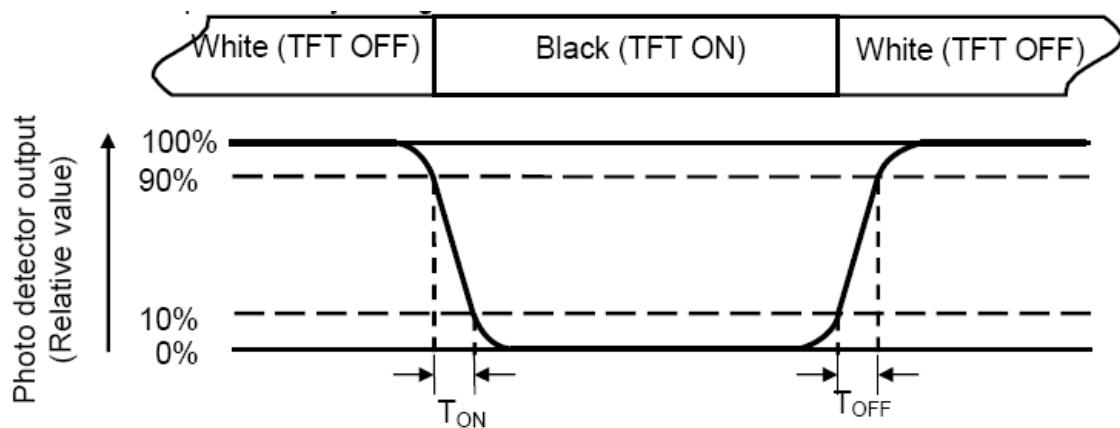

Note 5: Definition of color chromaticity (CIE1931)

Color coordinates measured at center point of LCD.



### Note 6: Definition of Luminance Uniformity

Active area is divided into 9 measuring areas (Refer Fig. 2). Every measuring point is placed at the center of each measuring area.

$$\text{Luminance Uniformity}(U) = L_{\min} / L_{\max}$$

L-----Active area length W----- Active area width

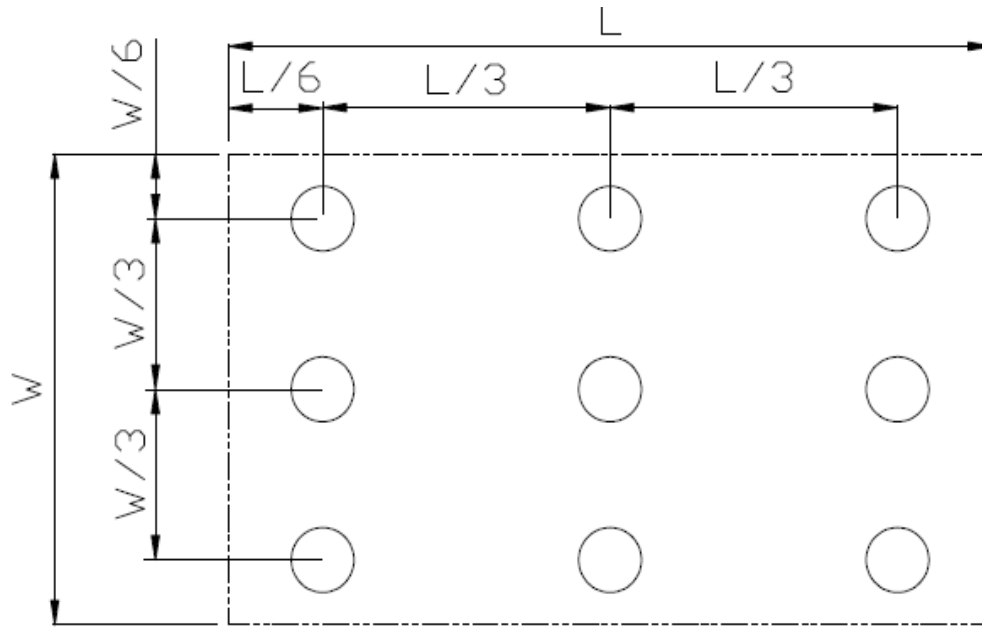

Fig. 2 Definition of uniformity

$L_{\max}$ : The measured maximum luminance of all measurement position.

$L_{\min}$ : The measured minimum luminance of all measurement position.

### Note 7: Definition of Luminance:

Measure the luminance of white state at center point.



## 7 Environmental / Reliability Tests

No	Test Item	Condition	Remarks
1	High Temperature Operation	Ts=+70°C, 240hrs	Note1 IEC60068-2-2,GB2423.2—89
2	Low Temperature Operation	Ta=-20°C, 240hrs	IEC60068-2-1 GB2423.1—89
3	High Temperature Storage	Ta=+80°C, 240hrs	IEC60068-2-2, GB2423.2—89
4	Low Temperature Storage	Ta=-30°C, 240hrs	IEC60068-2-1 GB2423.1—89
5	High Temperature & High Humidity Storage	Ta=+60°C, 90% RH 240 hours	Note2 IEC60068-2-3, GB/T2423.3—2006
6	Thermal Shock (Non-operation)	-30°C 30 min~+80°C 30 min, Change time:5min, 20 Cycles	Start with cold temperature, End with high temperature, IEC60068-2-14,GB2423.22—87
7	Electro Static Discharge (Operation)	C=150pF, R=330Ω, 5points/panel Air:±8KV, 5times; Contact:±4KV, 5 times; ( Environment: 15°C~35°C, 30%~60%, 86Kpa~106Kpa )	IEC61000-4-2 GB/T17626.2—1998
8	Vibration (Non-operation)	Frequency range:10~55Hz, Stroke:1.5mm Sweep:10Hz~55Hz~10Hz 2 hours for each direction of X.Y.Z. (6 hours for total)(Package condition)	IEC60068-2-6 GB/T2423.10—1995
9	Shock (Non-operation)	60G 6ms, ±X,±Y,±Z 3times, for each direction	IEC60068-2-27 GB/T2423.5—1995
10	Package Drop Test	Height:80 cm, 1 corner, 3 edges, 6 surfaces	IEC60068-2-32 GB/T2423.8—1995

Note1: Ts is the temperature of panel's surface.

Note2: Ta is the ambient temperature of sample.



8 Mechanical Drawing

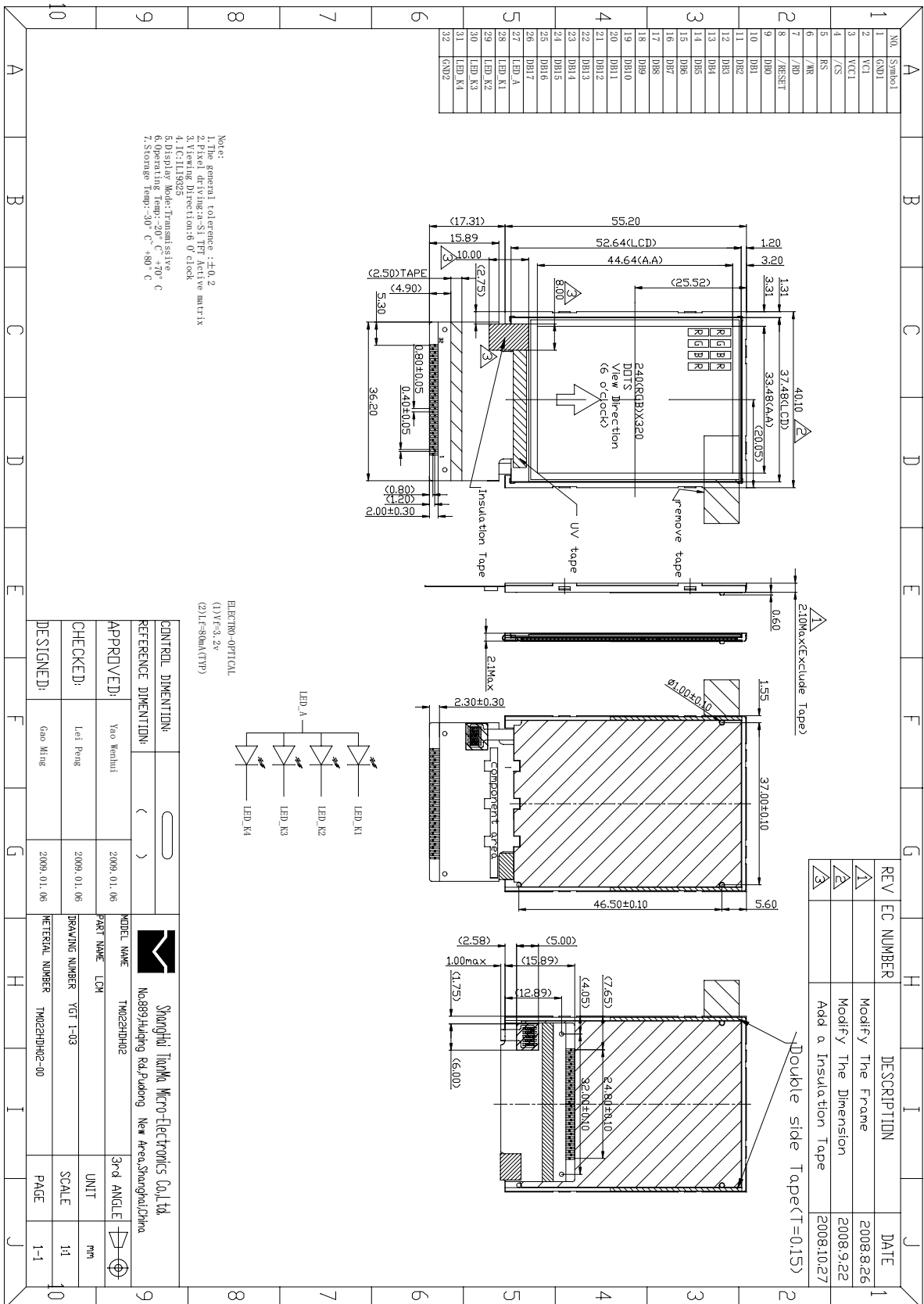

The information contained herein is the exclusive property of SHANGHAI TIANMA MICRO-ELECTRONICS Corporation, and shall not be distributed, reproduced, or disclosed in whole or in part without prior written permission of SHANGHAI TIANMA MICRO-ELECTRONICS Corporation.



### 9 Packing Drawing

No	Item	Model (Material)	Dimensions(mm)	Unit Weight(Kg)	Quantity	Remark
1	LCM module	TM022HDH02	40.1x55.2x2.1Max	0.0058	420	
2	Tray	PET ( Transmit )	485×330×12.8	0.166	18	Anti-static
3	Dust-Proof Bag	PE	700×545	0.05	1	
4	Box	Corrugated Paper	520X345X74	0.44	3	
5	Carton	Corrugated Paper	544×365×250	1.01	1	
6	EPE	EPE	485X330X5	0.08	6	
7	Total weight(kg)			8.284±5%		

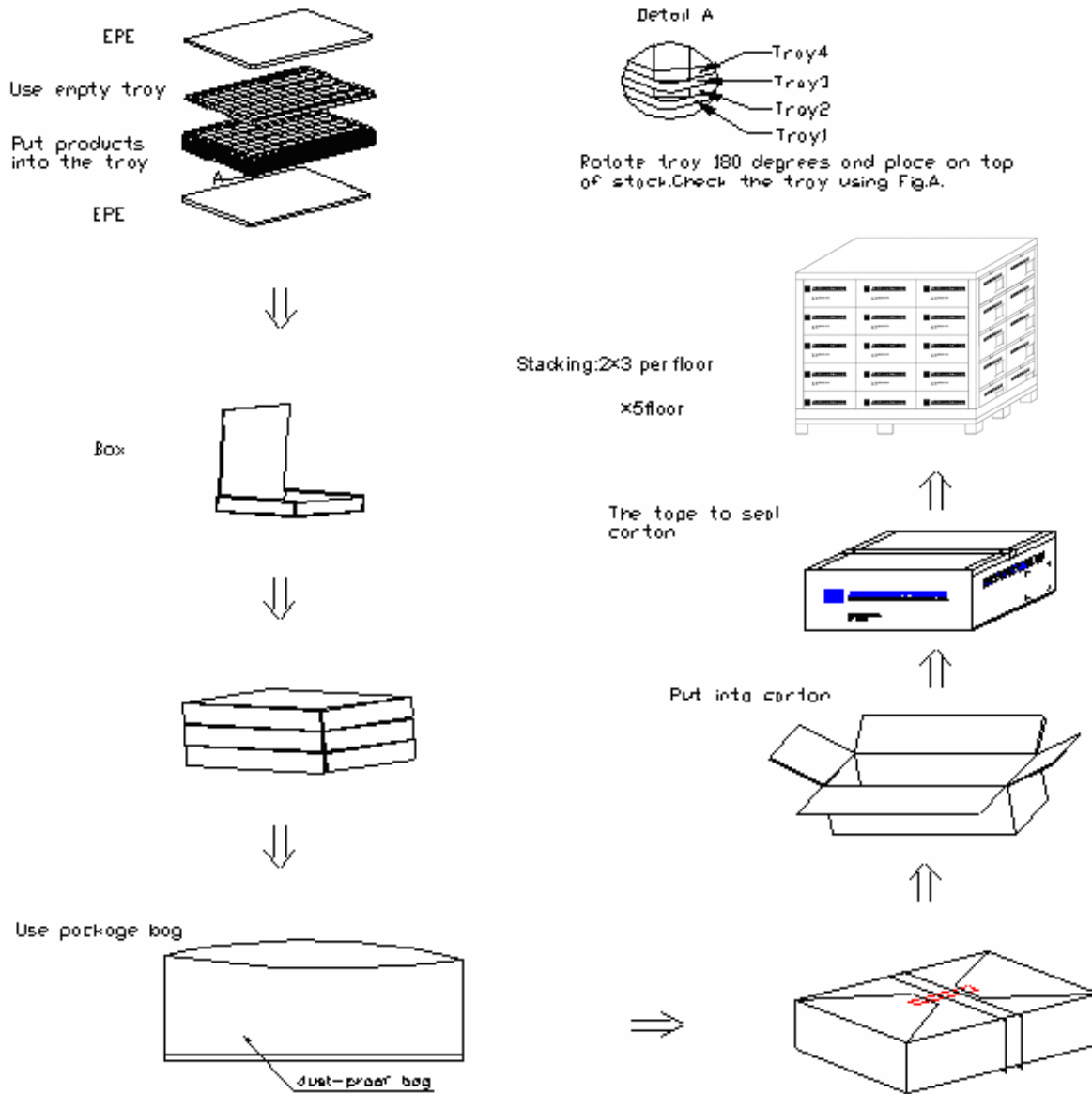

The information contained herein is the exclusive property of SHANGHAI TIANMA MICRO-ELECTRONICS Corporation, and shall not be distributed, reproduced, or disclosed in whole or in part without prior written permission of SHANGHAI TIANMA MICRO-ELECTRONICS Corporation.



## 10 Precautions for Use of LCD Modules

### 10.1 Handling Precautions

10.1.1 The display panel is made of glass. Do not subject it to a mechanical shock by dropping it from a high place, etc.

10.1.2 If the display panel is damaged and the liquid crystal substance inside it leaks out, be sure not to get any in your mouth, if the substance comes into contact with your skin or clothes, promptly wash it off using soap and water.

10.1.3 Do not apply excessive force to the display surface or the adjoining areas since this may cause the color tone to vary.

10.1.4 The polarizer covering the display surface of the LCD module is soft and easily scratched. Handle this polarizer carefully.

10.1.5 If the display surface is contaminated, breathe on the surface and gently wipe it with a soft dry cloth. If still not completely clear, moisten cloth with one of the following solvents:

- Isopropyl alcohol
- Ethyl alcohol

Solvents other than those mentioned above may damage the polarizer. Especially, do not use the following:

- Water
- Ketone
- Aromatic solvents

10.1.6 Do not attempt to disassemble the LCD Module.

10.1.7 If the logic circuit power is off, do not apply the input signals.

10.1.8 To prevent destruction of the elements by static electricity, be careful to maintain an optimum work environment.

10.1.8.1 Be sure to ground the body when handling the LCD Modules.

10.1.8.2 Tools required for assembly, such as soldering irons, must be properly ground.

10.1.8.3 To reduce the amount of static electricity generated, do not conduct assembly and other work under dry conditions.

10.1.8.4 The LCD Module is coated with a film to protect the display surface. Be care when peeling off this protective film since static electricity may be generated.

### 10.2 Storage precautions

10.2.1 When storing the LCD modules, avoid exposure to direct sunlight or to the light of fluorescent lamps.

10.2.2 The LCD modules should be stored under the storage temperature range. If the LCD modules will be stored for a long time, the recommend condition is:

Temperature : 0°C ~ 40°C      Relatively humidity: ≤80%

10.2.3 The LCD modules should be stored in the room without acid, alkali and harmful gas.

### 10.3 Transportation Precautions:

The LCD modules should be no falling and violent shocking during transportation, and also should avoid excessive press, water, damp and sunshine.