

Diagonal 3mm (Type 1/6) CCD Image Sensor for NTSC Color Video Cameras

**Description**

The ICX238AKC is an interline CCD solid-state image sensor suitable for NTSC small color video cameras. High resolution is achieved through the use of Ye, Cy, Mg, and G complementary color mosaic filters.

This chip features a field period readout system and an electronic shutter with variable charge-storage time.

The package is the smallest 12-pin SON (LCC).

**Features**

- High sensitivity and low smear
- Horizontal register: 3.3 to 5.0V drive
- Reset gate: 3.3 to 5.0V drive
- No voltage adjustment  
(Reset gate and substrate bias are not adjusted.)
- Low dark current and excellent antiblooming characteristics
- Continuous variable-speed shutter
- Recommended range of exit pupil distance: -10mm to  $-\infty$
- Ye, Cy, Mg, and G complementary color mosaic filters on chip
- 12-pin MID SON (LCC) package

**Device Structure**

- Interline CCD image sensor
- Image size: Diagonal 3mm (Type 1/6)
- Number of effective pixels: 768 (H)  $\times$  494 (V) approx. 380K pixels
- Total number of pixels: 811 (H)  $\times$  508 (V) approx. 410K pixels
- Chip size: 3.30mm (H)  $\times$  2.95mm (V)
- Unit cell size: 3.200 $\mu$ m (H)  $\times$  3.725 $\mu$ m (V)
- Optical black: Horizontal (H) direction: Front 3 pixels, rear 40 pixels  
Vertical (V) direction: Front 12 pixels, rear 2 pixels
- Number of dummy bits: Horizontal 22  
Vertical 1 (even fields only)
- Substrate material: Silicon

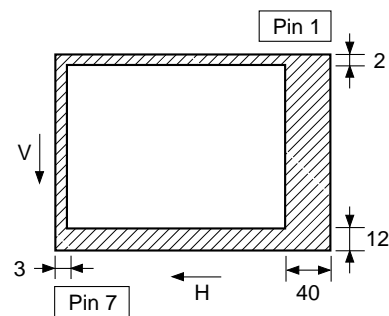
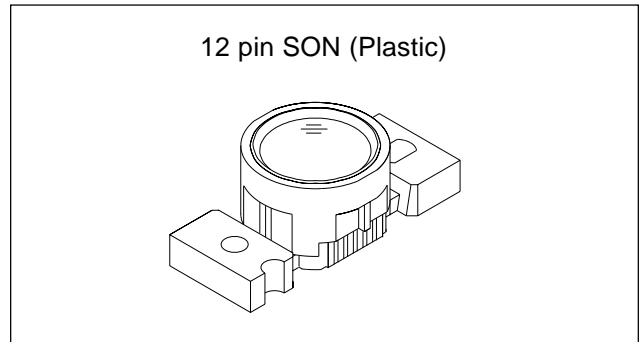

**Optical black position  
(Top View)**

Sony reserves the right to change products and specifications without prior notice. This information does not convey any license by any implication or otherwise under any patents or other right. Application circuits shown, if any, are typical examples illustrating the operation of the devices. Sony cannot assume responsibility for any problems arising out of the use of these circuits.

**Block Diagram and Pin Configuration**

(Top View)

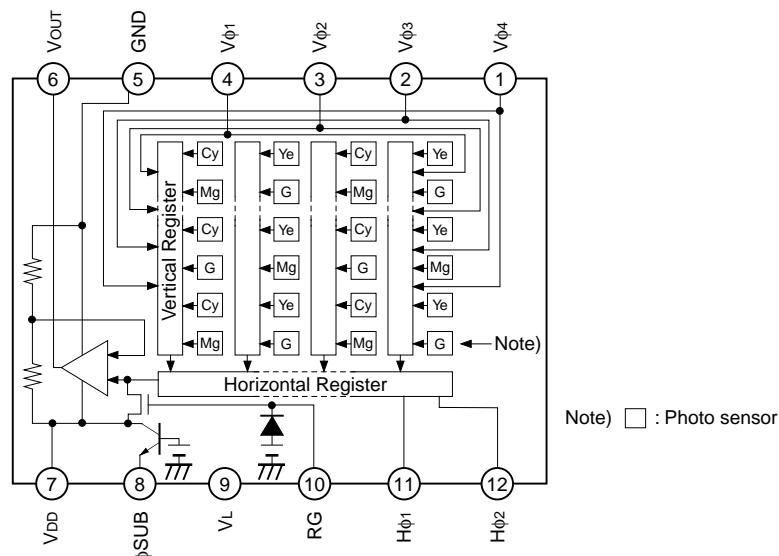

**Pin Description**

Pin No.	Symbol	Description	Pin No.	Symbol	Description
1	Vφ4	Vertical register transfer clock	7	V <sub>DD</sub>	Supply voltage
2	Vφ3	Vertical register transfer clock	8	φ <sub>SUB</sub>	Substrate clock
3	Vφ2	Vertical register transfer clock	9	V <sub>L</sub>	Protective transistor bias
4	Vφ1	Vertical register transfer clock	10	RG	Reset gate clock
5	GND	GND	11	Hφ1	Horizontal register transfer clock
6	V <sub>OUT</sub>	Signal output	12	Hφ2	Horizontal register transfer clock

**Absolute Maximum Ratings**

Item		Ratings	Unit	Remarks
Against φ <sub>SUB</sub>	V <sub>DD</sub> , V <sub>OUT</sub> , RG – φ <sub>SUB</sub>	-40 to +8	V	
	Vφ1, Vφ3 – φ <sub>SUB</sub>	-50 to +15	V	
	Vφ2, Vφ4, V <sub>L</sub> – φ <sub>SUB</sub>	-50 to +0.3	V	
	Hφ1, Hφ2, GND – φ <sub>SUB</sub>	-40 to +0.3	V	
Against GND	V <sub>DD</sub> , V <sub>OUT</sub> , RG – GND	-0.3 to +20	V	
	Vφ1, Vφ2, Vφ3, Vφ4 – GND	-10 to +18	V	
	Hφ1, Hφ2 – GND	-10 to +6	V	
Against V <sub>L</sub>	Vφ1, Vφ3 – V <sub>L</sub>	-0.3 to +28	V	
	Vφ2, Vφ4, Hφ1, Hφ2, GND – V <sub>L</sub>	-0.3 to +15	V	
Between input clock pins	Voltage difference between vertical clock input pins	to +15	V	*1
	Hφ1 – Hφ2	-6 to +6	V	
	Hφ1, Hφ2 – Vφ4	-14 to +14	V	
Storage temperature		-30 to +80	°C	
Operating temperature		-10 to +60	°C	

\*1 +24V (Max.) when clock width < 10μs, clock duty factor < 0.1%.

**Bias Conditions**

Item	Symbol	Min.	Typ.	Max.	Unit	Remarks
Supply voltage	V <sub>DD</sub>	14.55	15.0	15.45	V	
Protective transistor bias	V <sub>L</sub>	*1				
Substrate clock	φ <sub>SUB</sub>	*2				
Reset gate clock	φ <sub>RG</sub>	*2				

\*1 V<sub>L</sub> setting is the V<sub>VL</sub> voltage of the vertical transfer clock waveform, or the same power supply as the V<sub>L</sub> power supply for the V driver should be used.

\*2 Do not apply a DC bias to the substrate clock and reset gate clock pins, because a DC bias is generated within the CCD.

**DC Characteristics**

Item	Symbol	Min.	Typ.	Max.	Unit	Remarks
Supply current	I <sub>DD</sub>		3.5	5.5	mA	

**Clock Voltage Conditions**

Item	Symbol	Min.	Typ.	Max.	Unit	Waveform diagram	Remarks
Readout clock voltage	V <sub>VT</sub>	14.55	15.0	15.45	V	1	
Vertical transfer clock voltage	V <sub>VH1</sub> , V <sub>VH2</sub>	-0.05	0	0.05	V	2	V <sub>VH</sub> = (V <sub>VH1</sub> + V <sub>VH2</sub> )/2
	V <sub>VH3</sub> , V <sub>VH4</sub>	-0.2	0	0.05	V	2	
	V <sub>VL1</sub> , V <sub>VL2</sub> , V <sub>VL3</sub> , V <sub>VL4</sub>	-8.0	-7.5	-7.0	V	2	V <sub>VL</sub> = (V <sub>VL3</sub> + V <sub>VL4</sub> )/2
	V <sub>φV</sub>	6.8	7.5	8.05	V	2	V <sub>φV</sub> = V <sub>VHn</sub> - V <sub>VLn</sub> (n = 1 to 4)
	V <sub>VH3</sub> - V <sub>VH</sub>	-0.25		0.1	V	2	
	V <sub>VH4</sub> - V <sub>VH</sub>	-0.25		0.1	V	2	
	V <sub>VHH</sub>			0.3	V	2	High-level coupling
	V <sub>VHL</sub>			0.3	V	2	High-level coupling
	V <sub>VLH</sub>			0.3	V	2	Low-level coupling
	V <sub>VLL</sub>			0.3	V	2	Low-level coupling
Horizontal transfer clock voltage	V <sub>φH</sub>	3.0	3.3	5.25	V	3	
	V <sub>HL</sub>	-0.05	0	0.05	V	3	
Reset gate clock voltage	V <sub>φRG</sub>	3.0	3.3	5.5	V	4	Input through 0.1μF capacitance
	V <sub>RGLH</sub> - V <sub>RGLL</sub>			0.4	V	4	Low-level coupling
	V <sub>RGL</sub> - V <sub>RGLm</sub>			0.5	V	4	Low-level coupling
Substrate clock voltage	V <sub>φSUB</sub>	21.5	22.5	23.5	V	5	

**Clock Equivalent Circuit Constant**

Item	Symbol	Min.	Typ.	Max.	Unit	Remarks
Capacitance between vertical transfer clock and GND	$C\phi_{V1}, C\phi_{V3}$		680		pF	
	$C\phi_{V2}, C\phi_{V4}$		220		pF	
Capacitance between vertical transfer clocks	$C\phi_{V12}, C\phi_{V34}$		91		pF	
	$C\phi_{V23}, C\phi_{V41}$		75		pF	
	$C\phi_{V13}, C\phi_{V24}$		30		pF	
Capacitance between horizontal transfer clock and GND	$C\phi_{H1}, C\phi_{H2}$		13		pF	
Capacitance between horizontal transfer clocks	$C\phi_{HH}$		34		pF	
Capacitance between reset gate clock and GND	$C\phi_{RG}$		5		pF	
Capacitance between substrate clock and GND	$C\phi_{SUB}$		180		pF	
Vertical transfer clock series resistor	$R_1, R_2, R_3, R_4$		120		$\Omega$	
Vertical transfer clock ground resistor	$R_{GND}$		15		$\Omega$	
Horizontal transfer clock series resistor	$R\phi_H$		15		$\Omega$	
Reset gate clock series resistor	$R\phi_{RG}$		51		$\Omega$	

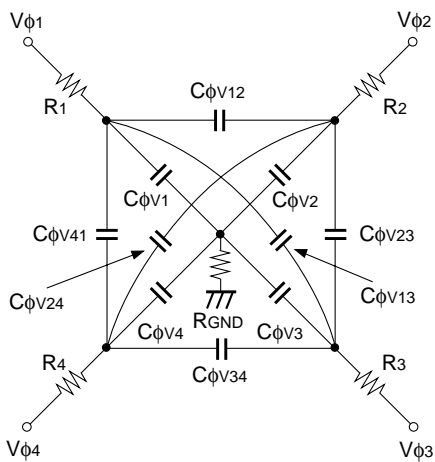

**Vertical transfer clock equivalent circuit**

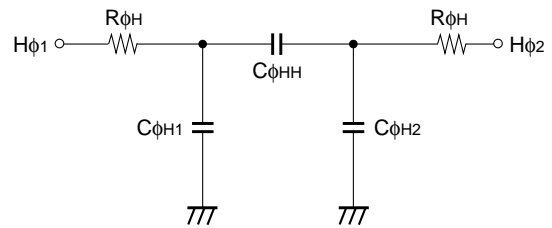

**Horizontal transfer clock equivalent circuit**

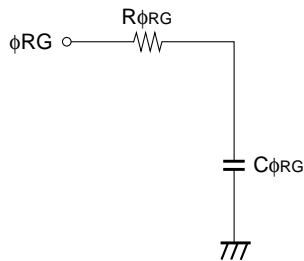

**Reset gate clock equivalent circuit**

Drive Clock Waveform Conditions

(1) Readout clock waveform

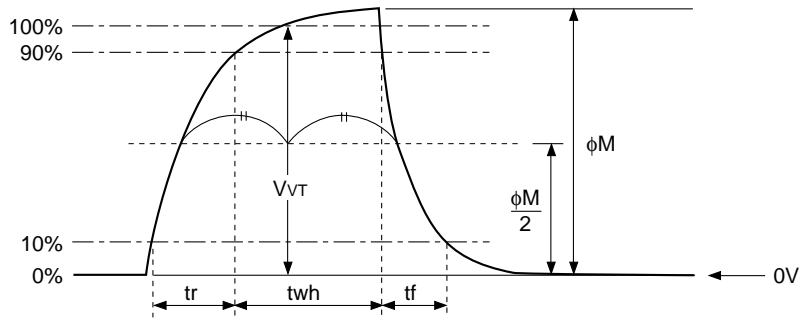

(2) Vertical transfer clock waveform

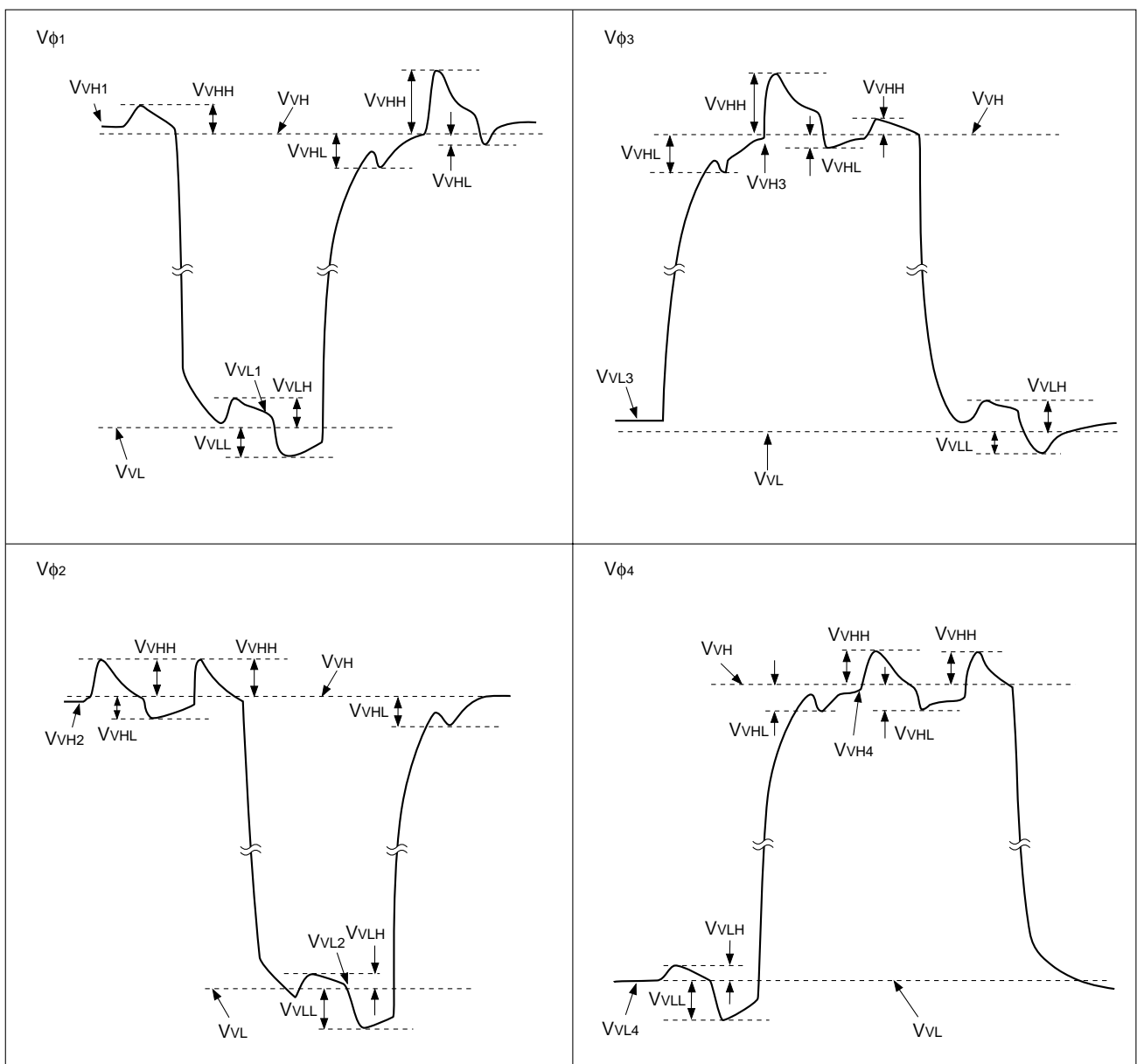

$$V_{VH} = (V_{VH1} + V_{VH2})/2$$

$$V_{VL} = (V_{VL3} + V_{VL4})/2$$

$$V_{\phi n} = V_{VHN} - V_{VLn} \quad (n = 1 \text{ to } 4)$$

**(3) Horizontal transfer clock waveform**

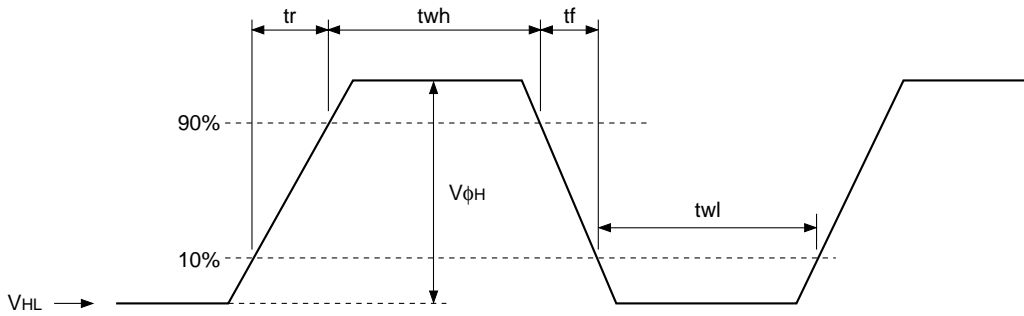

**(4) Reset gate clock waveform**

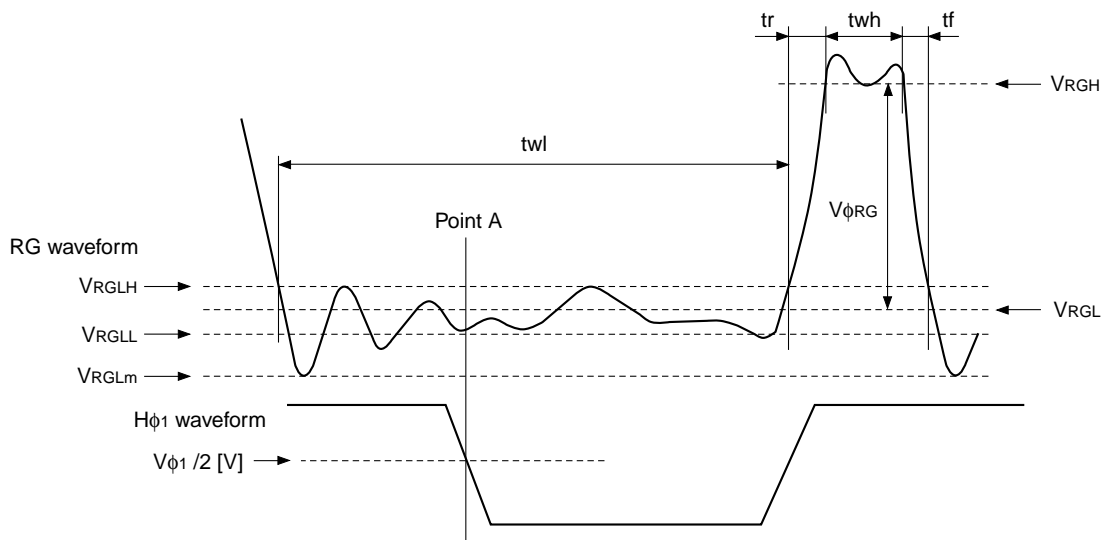

$V_{RGLH}$  is the maximum value and  $V_{RGLL}$  is the minimum value of the coupling waveform during the period from Point A in the above diagram until the rising edge of RG. In addition,  $V_{RGL}$  is the average value of  $V_{RGLH}$  and  $V_{RGLL}$ .

$$V_{RGL} = (V_{RGLH} + V_{RGLL})/2$$

Assuming  $V_{RGH}$  is the minimum value during the interval  $t_{wh}$ , then:

$$V_{\phi RG} = V_{RGH} - V_{RGL}$$

Negative overshoot level during the falling edge of RG is  $V_{RGLm}$ .

**(5) Substrate clock waveform**

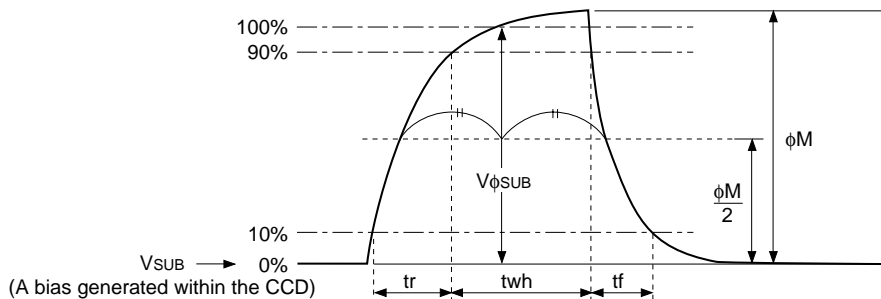

**Clock Switching Characteristics**

Item	Symbol	twh			twl			tr			tf			Unit	Remarks	
		Min.	Typ.	Max.	Min.	Typ.	Max.	Min.	Typ.	Max.	Min.	Typ.	Max.			
Readout clock	V <sub>T</sub>	2.3	2.5						0.5			0.5		μs	During readout	
Vertical transfer clock	V <sub>φ1</sub> , V <sub>φ2</sub> , V <sub>φ3</sub> , V <sub>φ4</sub>										15		250	ns	*1	
Horizontal transfer clock	During imaging	H <sub>φ1</sub>	26	28.5		26	28.5			6.5	9.5		6.5	9.5	ns	*2
		H <sub>φ2</sub>	26	28.5		26	28.5			6.5	9.5		6.5	9.5		
	During parallel-serial conversion	H <sub>φ1</sub>		5.38						0.01			0.01		μs	
		H <sub>φ2</sub>					5.38			0.01			0.01			
Reset gate clock	φ <sub>RG</sub>	11	13			51			3			3		ns		
Substrate clock	φ <sub>SUB</sub>	1.5	1.8							0.5			0.5	μs	During drain charge	

\*1 When vertical transfer clock driver CXD1267AN is used.

\*2 When V<sub>φH</sub> = 3.0V. tf ≥ tr – 2ns, and the cross-point voltage (V<sub>CR</sub>) for the H<sub>φ1</sub> rising side of the H<sub>φ1</sub> and H<sub>φ2</sub> waveforms must be at least V<sub>φH</sub>/2 [V].

Item	Symbol	two			Unit	Remarks
		Min.	Typ.	Max.		
Horizontal transfer clock	H <sub>φ1</sub> , H <sub>φ2</sub>	22	26		ns	*3

\*3 The overlap period of twh and twl of horizontal transfer clocks H<sub>φ1</sub> and H<sub>φ2</sub> is two.

Image Sensor Characteristics

(Ta = 25°C)

Item	Symbol	Min.	Typ.	Max.	Unit	Measurement method	Remarks
Sensitivity	S	240	300		mV	1	
Sensitivity ratio	R <sub>MgG</sub>	0.93		1.35		2	
	R <sub>YeCy</sub>	1.15		1.48		2	
Saturation signal	Y <sub>sat</sub>	600			mV	3	Ta = 60°C
Smear	Sm		0.009	0.015	%	4	
Video signal shading	SHy			20	%	5	Zone 0 and I
				25	%	5	Zone 0 to II'
Uniformity between video signal channels	ΔSr			10	%	6	
	ΔSb			10	%	6	
Dark signal	Y <sub>dt</sub>			2	mV	7	Ta = 60°C
Flicker Y	Fy			2	%	8	
Flicker R-Y	Fcr			5	%	8	
Flicker B-Y	Fcb			5	%	8	
Line crawl R	Lcr			3	%	9	
Line crawl G	Lcg			3	%	9	
Line crawl B	Lcb			3	%	9	
Line crawl W	Lcw			3	%	9	

Zone Definition of Video Signal Shading

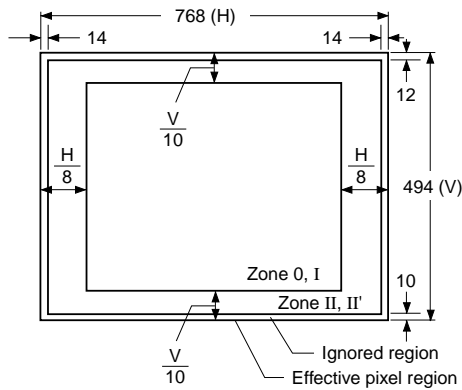

Measurement System

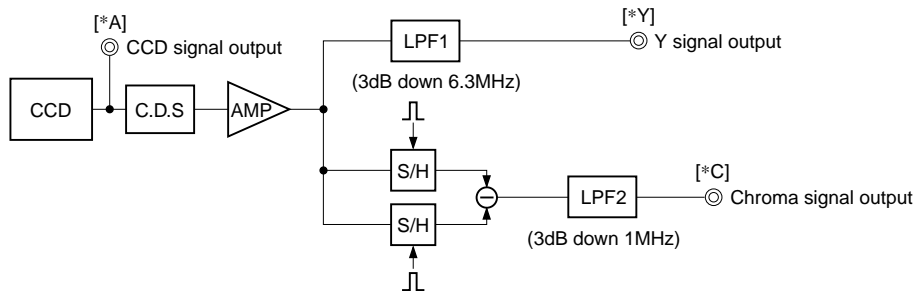

**Note)** Adjust the amplifier gain so that the gain between [\*A] and [\*Y], and between [\*A] and [\*C] equals 1.

**Image Sensor Characteristics Measurement Method**

◎ **Measurement conditions**

- 1) In the following measurements, the device drive conditions are at the typical values of the bias and clock voltage conditions.
- 2) In the following measurements, spot blemishes are excluded and, unless otherwise specified, the optical black level (OB) is used as the reference for the signal output, which is taken as the value of Y signal output or chroma signal output of the measurement system.

◎ **Color coding of this image sensor & Composition of luminance (Y) and chroma (color difference) signals**

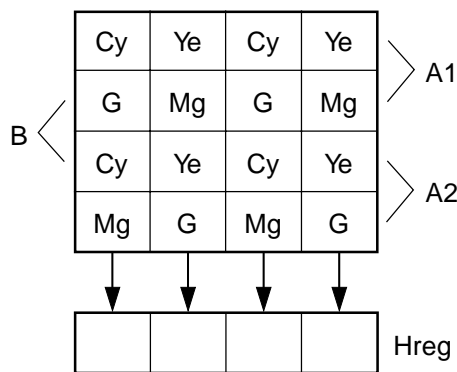

As shown in the left figure, fields are read out. The charge is mixed by pairs such as A1 and A2 in the A field. (pairs such as B in the B field)

As a result, the sequence of charges output as signals from the horizontal shift register (Hreg) is, for line A1, (G + Cy), (Mg + Ye), (G + Cy), and (Mg + Ye).

**Color Coding Diagram**

These signals are processed to form the Y signal and chroma (color difference) signal. The Y signal is formed by adding adjacent signals, and the chroma signal is formed by subtracting adjacent signals. In other words, the approximation:

$$Y = \{(G + Cy) + (Mg + Ye)\} \times 1/2$$

$$= 1/2 \{2B + 3G + 2R\}$$

is used for the Y signal, and the approximation:

$$R - Y = \{(Mg + Ye) - (G + Cy)\}$$

$$= \{2R - G\}$$

is used for the chroma (color difference) signal. For line A2, the signals output from Hreg in sequence are (Mg + Cy), (G + Ye), (Mg + Cy), (G + Ye).

The Y signal is formed from these signals as follows:

$$Y = \{(G + Ye) + (Mg + Cy)\} \times 1/2$$

$$= 1/2 \{2B + 3G + 2R\}$$

This is balanced since it is formed in the same way as for line A1.

In a like manner, the chroma (color difference) signal is approximated as follows:

$$-(B - Y) = \{(G + Ye) - (Mg + Cy)\}$$

$$= -\{2B - G\}$$

In other words, the chroma signal can be retrieved according to the sequence of lines from R - Y and -(B - Y) in alternation. This is also true for the B field.

## ◎ Definition of standard imaging conditions

### 1) Standard imaging condition I:

Use a pattern box (luminance 706cd/m<sup>2</sup>, color temperature of 3200K halogen source) as a subject. (Pattern for evaluation is not applicable.) Use a testing standard lens with CM500S (t = 1.0mm) as an IR cut filter and image at F5.6. The luminous intensity to the sensor receiving surface at this point is defined as the standard sensitivity testing luminous intensity.

### 2) Standard imaging condition II:

Image a light source (color temperature of 3200K) with a uniformity of brightness within 2% at all angles. Use a testing standard lens with CM500S (t = 1.0mm) as an IR cut filter. The luminous intensity is adjusted to the value indicated in each testing item by the lens diaphragm.

### 3) Standard imaging condition III:

Image a light source (color temperature of 3200K) with a uniformity of brightness within 2% at all angles. Use a testing standard lens (exit pupil distance –33mm) with CM500S (t = 1.0mm) as an IR cut filter. The luminous intensity is adjusted to the value indicated in each testing item by the lens diaphragm.

## 1. Sensitivity

Set to standard imaging condition I. After selecting the electronic shutter mode with a shutter speed of 1/250s, measure the Y signal (Y<sub>s</sub>) at the center of the screen and substitute the value into the following formula.

$$S = Y_s \times \frac{250}{60} \text{ [mV]}$$

## 2. Sensitivity ratio

Set to standard imaging condition II. Adjust the luminous intensity so that the average value of the Y signal output is 200mV, and then measure the Mg signal output (S<sub>Mg</sub> [mV]) and G signal output (S<sub>G</sub> [mV]), and Ye signal output (S<sub>Ye</sub> [mV]) and Cy signal output (S<sub>Cy</sub> [mV]) at the center of the screen with frame readout method. Substitute the values into the following formula.

$$R_{MgG} = S_{Mg}/S_G$$

$$R_{YeCy} = S_{Ye}/S_{Cy}$$

## 3. Saturation signal

Set to standard imaging condition II. After adjusting the luminous intensity to 10 times the intensity with average value of the Y signal output, 200mV, measure the minimum value of the Y signal.

## 4. Smear

Set to standard imaging condition II. With the lens diaphragm at F5.6 to F8, adjust the luminous intensity to 500 times the intensity with average value of the Y signal output, 200mV. When the readout clock is stopped and the charge drain is executed by the electronic shutter at the respective H blankings, measure the maximum value (Y<sub>Sm</sub> [mV]) of the Y signal output and substitute the value into the following formula.

$$S_m = \frac{Y_{Sm}}{200} \times \frac{1}{500} \times \frac{1}{10} \times 100 \text{ [%]} \text{ (1/10V method conversion value)}$$

## 5. Video signal shading

Set to standard imaging condition III. With the lens diaphragm at F5.6 to F8, adjust the luminous intensity so that the average value of the Y signal output is 200mV. Then measure the maximum (Ymax [mV]) and minimum (Ymin [mV]) values of the Y signal and substitute the values into the following formula.

$$SH_y = (Y_{\max} - Y_{\min})/200 \times 100 [\%]$$

## 6. Uniformity between video signal channels

Set to standard imaging condition II. Adjust the luminous intensity so that the average value of the Y signal output is 200mV, and then measure the maximum (Crmax, Cbmax [mV]) and minimum (Crmin, Cbmin [mV]) values of the R – Y and B – Y channels of the chroma signal and substitute the values into the following formula.

$$\Delta Sr = | (Cr_{\max} - Cr_{\min})/200 | \times 100 [\%]$$

$$\Delta Sb = | (Cb_{\max} - Cb_{\min})/200 | \times 100 [\%]$$

## 7. Dark signal

Measure the average value of the Y signal output (Ydt [mV]) with the device ambient temperature 60°C and the device in the light-obstructed state, using the horizontal idle transfer level as a reference.

## 8. Flicker

## 1) Fy

Set to standard imaging condition II. Adjust the luminous intensity so that the average value of the Y signal output is 200mV, and then measure the difference in the signal level between fields ( $\Delta Y_f$  [mV]). Then substitute the value into the following formula.

$$F_y = (\Delta Y_f/200) \times 100 [\%]$$

## 2) Fcr, Fcb

Set to standard imaging condition II. Adjust the luminous intensity so that the average value of the Y signal output is 200mV, insert an R or B filter, and then measure both the difference in the signal level between fields of the chroma signal ( $\Delta C_r$ ,  $\Delta C_b$ ) as well as the average value of the chroma signal output (CAr, CAb). Substitute the values into the following formula.

$$F_{ci} = (\Delta C_i/CA_i) \times 100 [\%] \quad (i = r, b)$$

## 9. Line crawls

Set to standard imaging condition II. Adjust the luminous intensity so that the average value of the Y signal output is 200mV, and then insert a white subject and R, G, and B filters and measure the difference between Y signal lines for the same field ( $\Delta Y_{lw}$ ,  $\Delta Y_{lr}$ ,  $\Delta Y_{lg}$ ,  $\Delta Y_{lb}$  [mV]). Substitute the values into the following formula.

$$L_{ci} = (\Delta Y_{li}/200) \times 100 [\%] \quad (i = w, r, g, b)$$

Drive Circuit

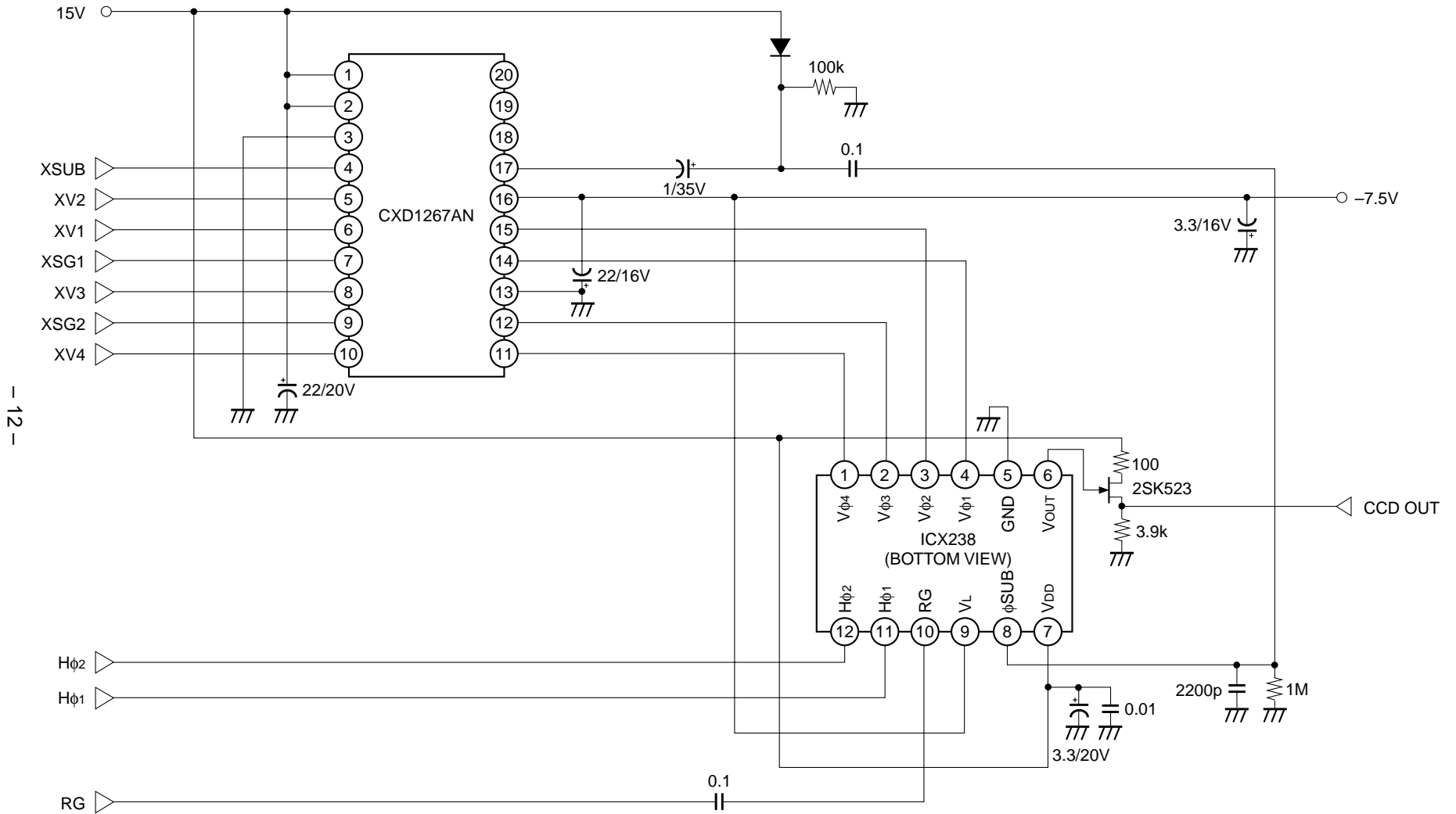

**Spectral Sensitivity Characteristics** (excludes both lens characteristics and light source characteristics)

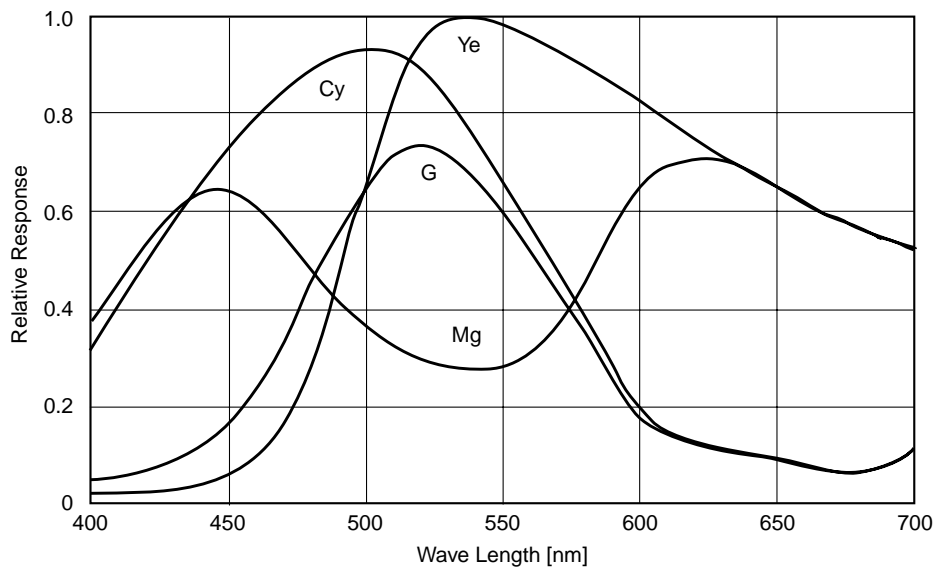

**Sensor Readout Clock Timing Chart**

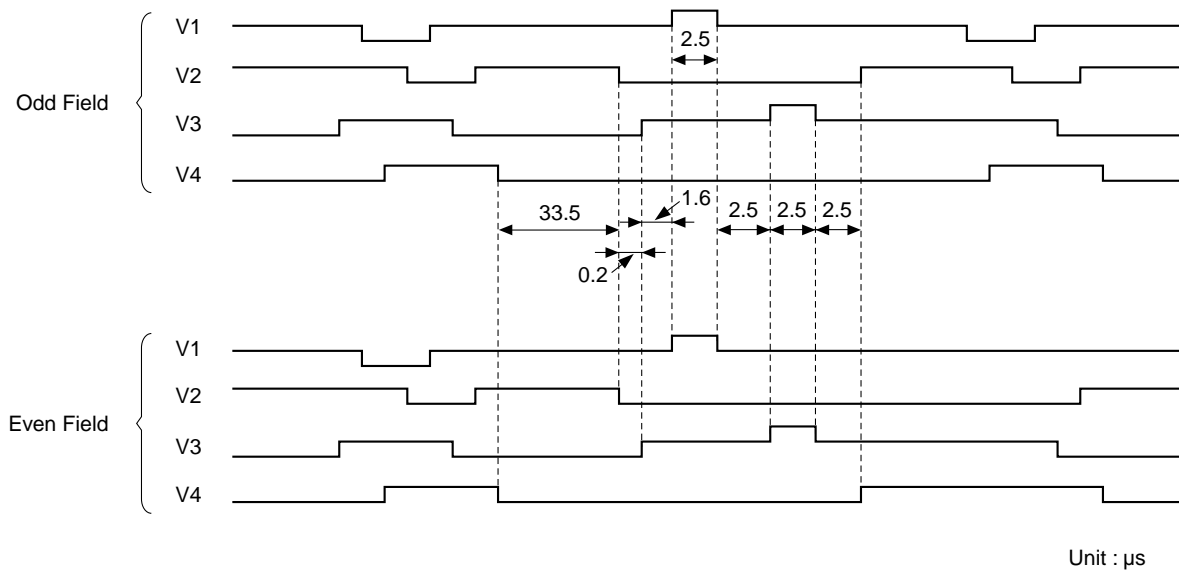

Drive Timing Chart (Vertical Sync)

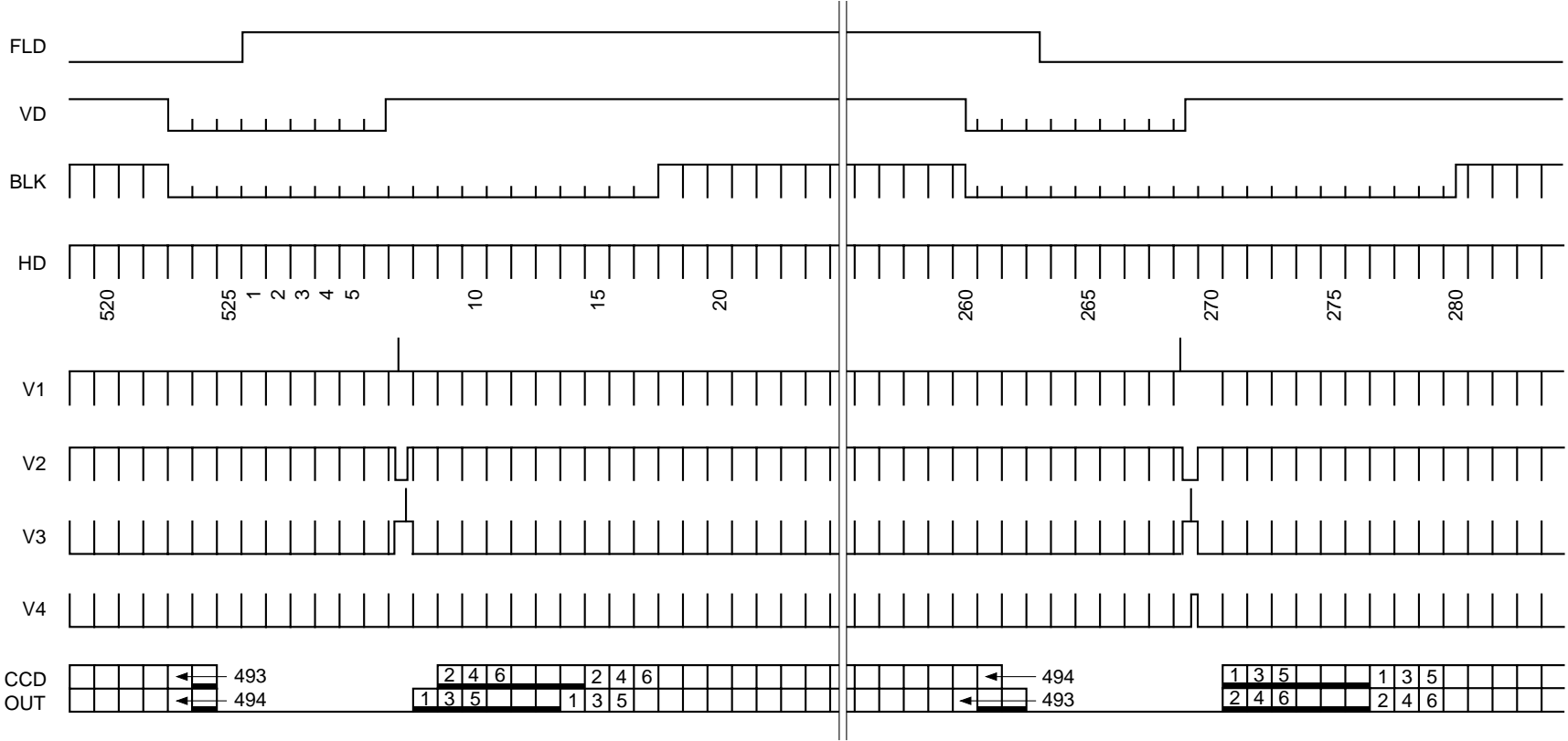

Drive Timing Chart (Horizontal Sync)

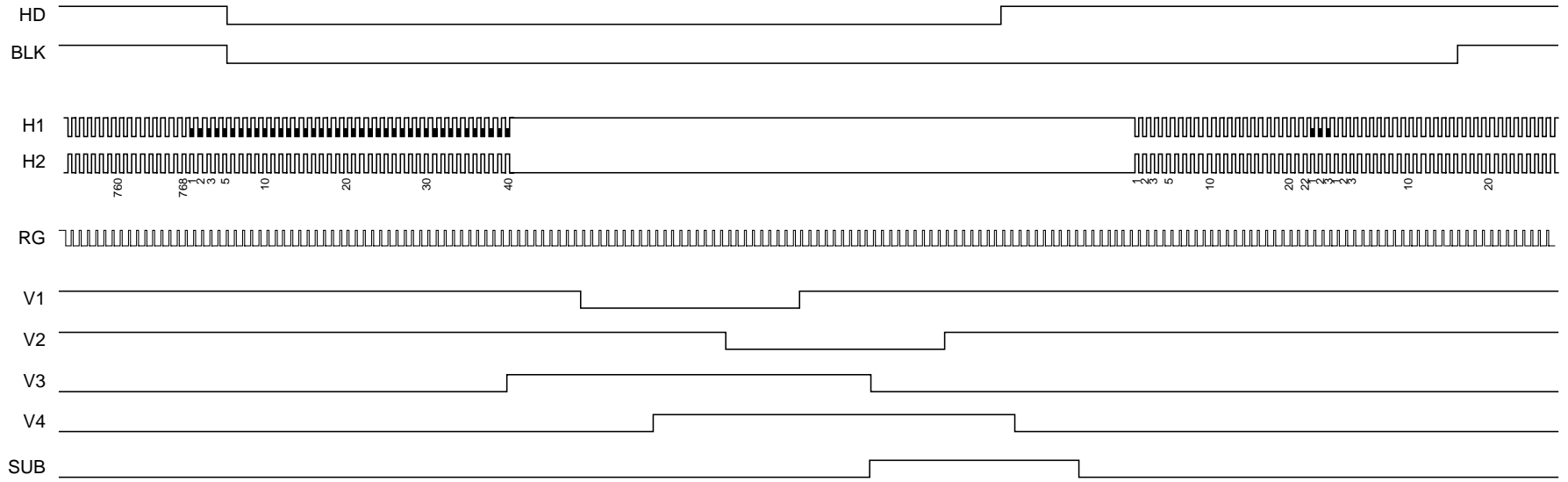

## Notes on Handling

### 1) Moisture resistance

As the moisture resistance of this CCD is not guaranteed, be sure to consider the moisture resistance at the set built in this CCD.

### 2) Static charge prevention

CCD image sensors are easily damaged by static discharge. Before handling be sure to take the following protective measures.

a) Either handle bare handed or use non-chargeable gloves, clothes or material.

Also use conductive shoes.

b) When handling directly, use an earth band.

c) Install a conductive mat on the floor or working table to prevent the generation of static electricity.

d) Ionized air is recommended for discharge when handling CCD image sensor.

e) For the shipment of mounted substrates, use boxes treated for the prevention of static charges.

### 3) Soldering

a) Make sure that the temperature of the cap on the ceramic package does not exceed 80°C.

b) Solder dipping in a mounting furnace causes damage to the glass and other defects. Use a 30W soldering iron with a ground wire and solder each pin in less than 2 seconds. For repairs and remount, cool sufficiently.

c) To dismount an image sensor, do not use a solder suction equipment. When using an electric desoldering tool, use a thermal controller of the zero cross On/Off type and connect it to ground.

### 4) Dust and dirt protection

Image sensors are packed and delivered by taking care of protecting its glass plates from harmful dust and dirt. Clean glass plates with the following operation as required, and use them.

a) Perform all assembly operations in a clean room (class 1000 or less).

b) Do not either touch glass plates by hand or have any object come in contact with glass surfaces. Should dirt stick to a glass surface, blow it off with an air blower. (For dirt stuck through static electricity, ionized air is recommended.)

c) Clean with a cotton bud and ethyl alcohol if the grease stained. Be careful not to scratch the glass.

d) Keep in a case to protect from dust and dirt. To prevent dew condensation, preheat or precool when moving to a room with great temperature differences.

### 5) Installing (attaching)

a) If a load is applied to the entire surface by a hard component, bending stress may be generated and the package may fracture, etc., depending on the flatness of the bottom of the package. Therefore, for installation, use either an elastic load, such as a spring plate, or an adhesive.

b) If the metal, etc., clash or rub against the package, the dust may be generated by the fragments of package.

c) Acrylate anaerobic adhesives are generally used to attach CCD image sensors. In addition, cyano-acrylate instantaneous adhesives are sometimes used jointly with acrylate anaerobic adhesives. (reference)

## 6) Others

- a) Do not expose to strong light (sun rays) for long periods, color filters will be discolored. When high luminance objects are imaged with the exposure level control by electronic-iris, the luminance of the image-plane may become excessive and discolor of the color filter will possibly be accelerated. In such a case, it is advisable that taking-lens with the automatic-iris and closing of the shutter during the power-off mode should be properly arranged. For continuous using under cruel condition exceeding the normal using condition, consult our company.
- b) Exposure to high temperature or humidity will affect the characteristics. Accordingly avoid storage or usage in such conditions.
- c) The cap is put on the package with light pressure but not sticked by adhesive. Be careful not to add shock to the chip. The cap of this CCD should not be removed. If the cap is removed, the characteristics of the CCD is not guaranteed.
- d) The center point and the rotation angle of the effective image area after taking off the location hole and the long hole, are not guaranteed. If necessary, we recommend to carry out the acceptance inspection.
- e) The marking is not indicated on the surface of this CCD. Special care should be taken for the management of the stored CCD. If necessary, we recommend to carry out the acceptance inspection.

